

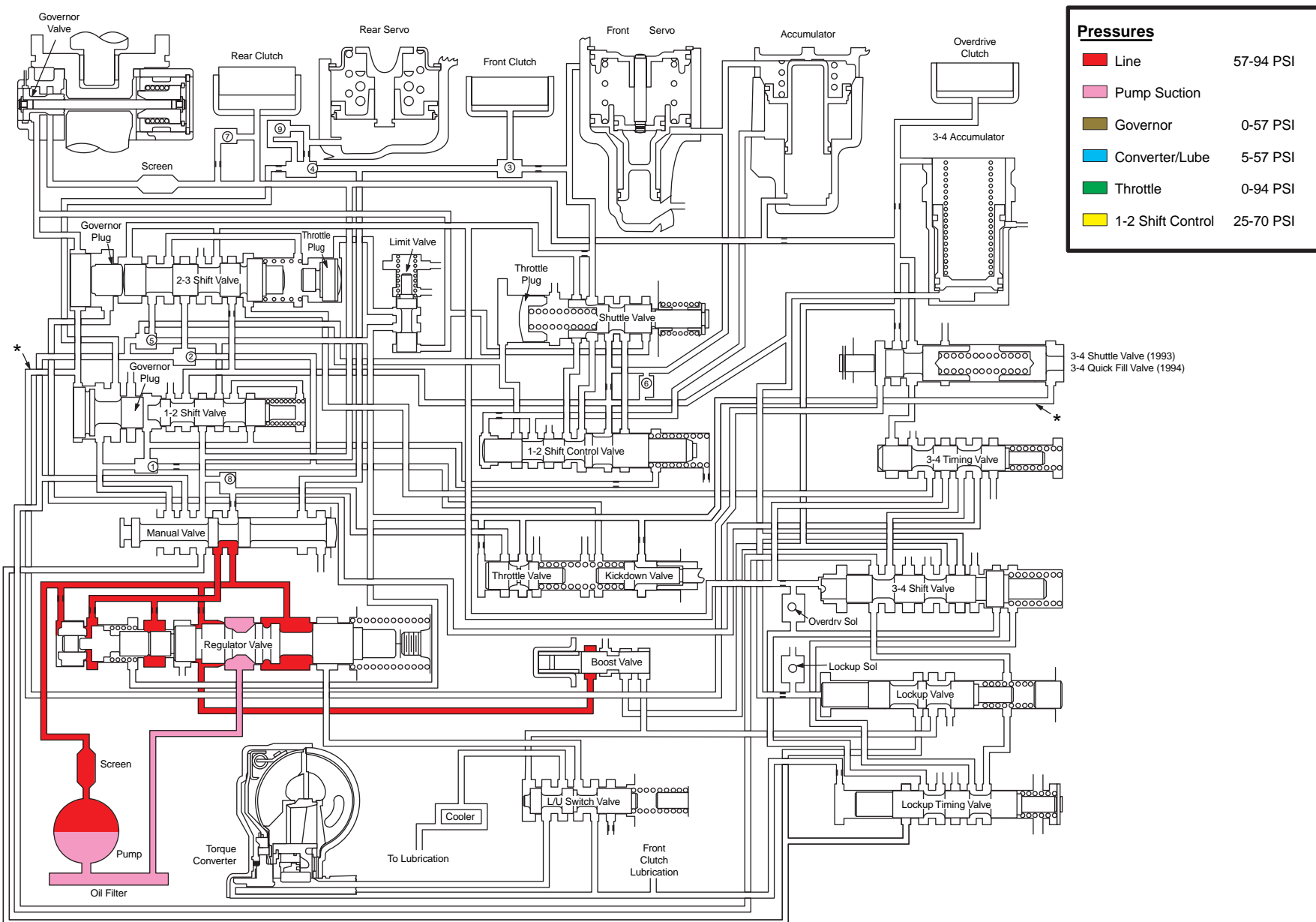

# Chrysler 42RH & 46RH

## Park - "P" Range



Pressures	
Line	57-94 PSI
Pump Suction	
Governor	0-57 PSI
Converter/Lube	5-57 PSI
Throttle	0-94 PSI
1-2 Shift Control	25-70 PSI

3-4 Shuttle Valve (1993)  
3-4 Quick Fill Valve (1994)

\*

\*

Oil Filter

Pump

Screen

Regulator Valve

Manual Valve

1-2 Shift Valve

2-3 Shift Valve

Screen

Governor Valve

Rear Clutch

Rear Servo

Torque Converter

To Lubrication

Cooler

Front Clutch Lubrication

L/U Switch Valve

Boost Valve

Throttle Valve

Kickdown Valve

Throttle Plug

Shuttle Valve

1-2 Shift Control Valve

3-4 Timing Valve

3-4 Shift Valve

Lockup Valve

Lockup Timing Valve

Overdr Sol

Lockup Sol

3-4 Accumulator

Accumulator

Front Servo

Rear Servo

Overdrive Clutch

3-4 Accumulator

Accumulator

Front Servo

Rear Servo

Overdrive Clutch

# Chrysler 42RH & 46RH

## Reversel - "R" Range

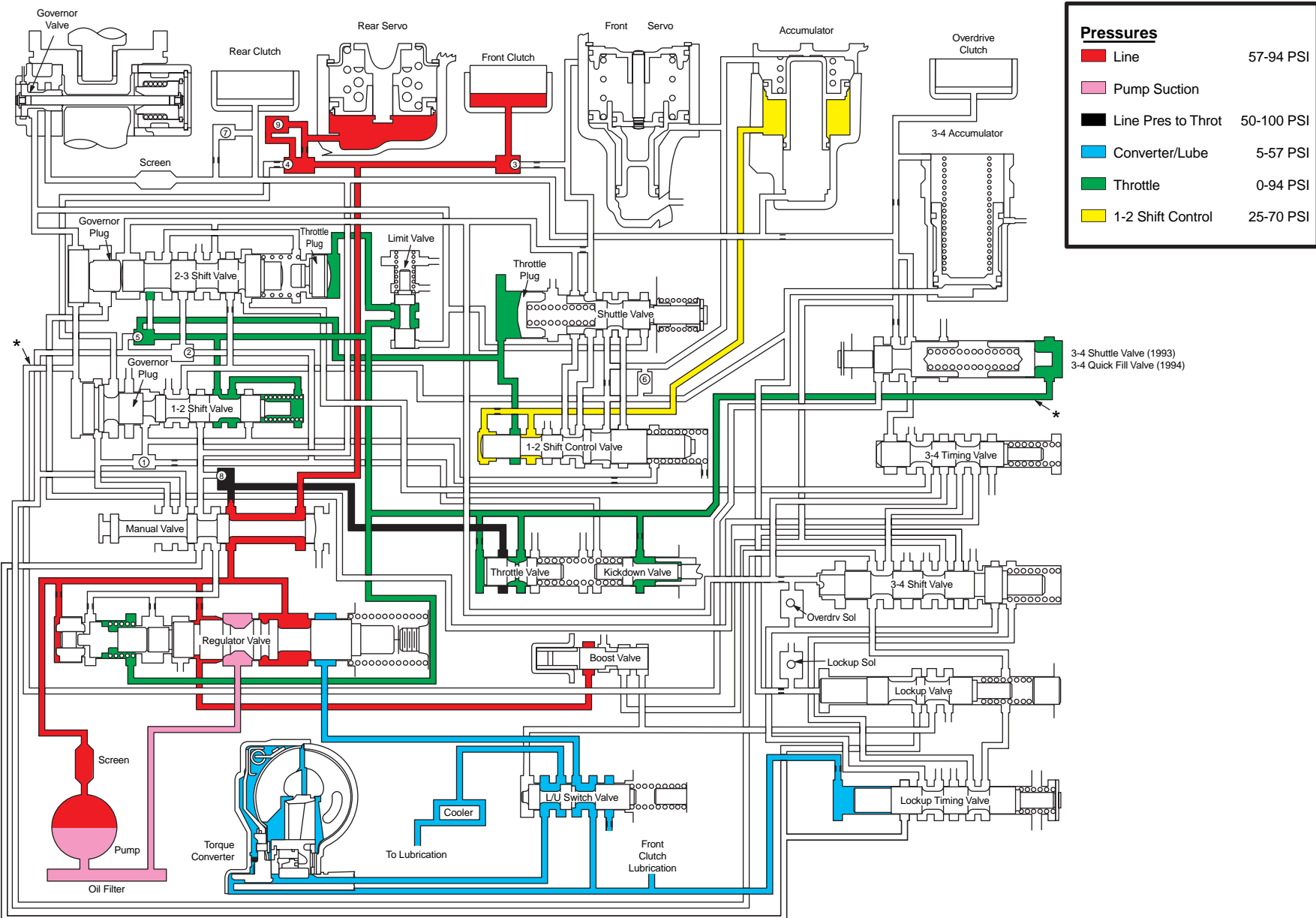

Pressures	
<span style="color: red;">█</span> Line	57-94 PSI
<span style="color: pink;">█</span> Pump Suction	
<span style="color: black;">█</span> Line Pres to Throt	50-100 PSI
<span style="color: blue;">█</span> Converter/Lube	5-57 PSI
<span style="color: green;">█</span> Throttle	0-94 PSI
<span style="color: yellow;">█</span> 1-2 Shift Control	25-70 PSI

3-4 Shuttle Valve (1993)  
 3-4 Quick Fill Valve (1994)

\*

\*

# Chrysler 42RH & 46RH

## 1st Gear - "L" Range

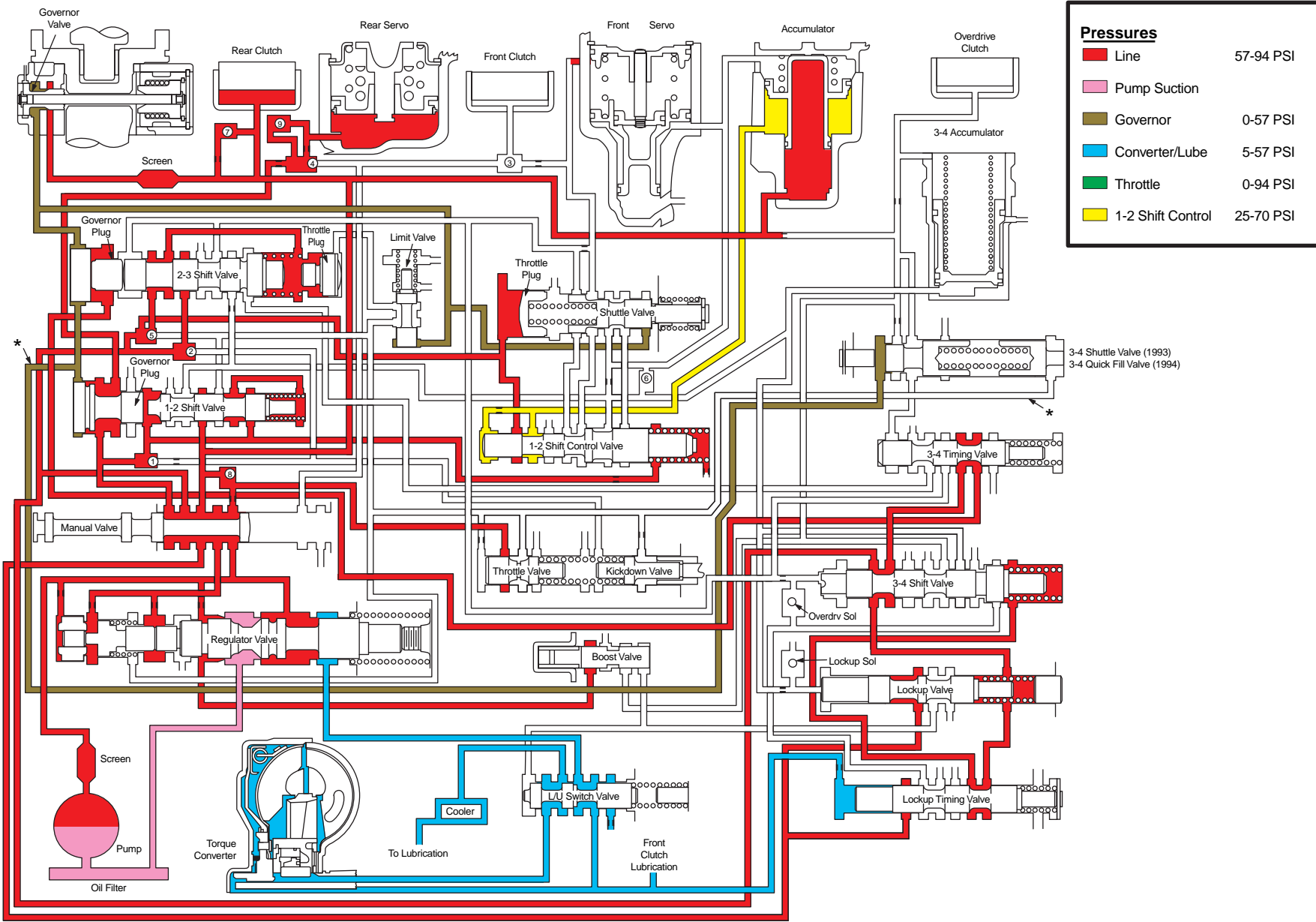

# Chrysler 42RH & 46RH

## 2nd Gear (Manual Select) - "2" Range

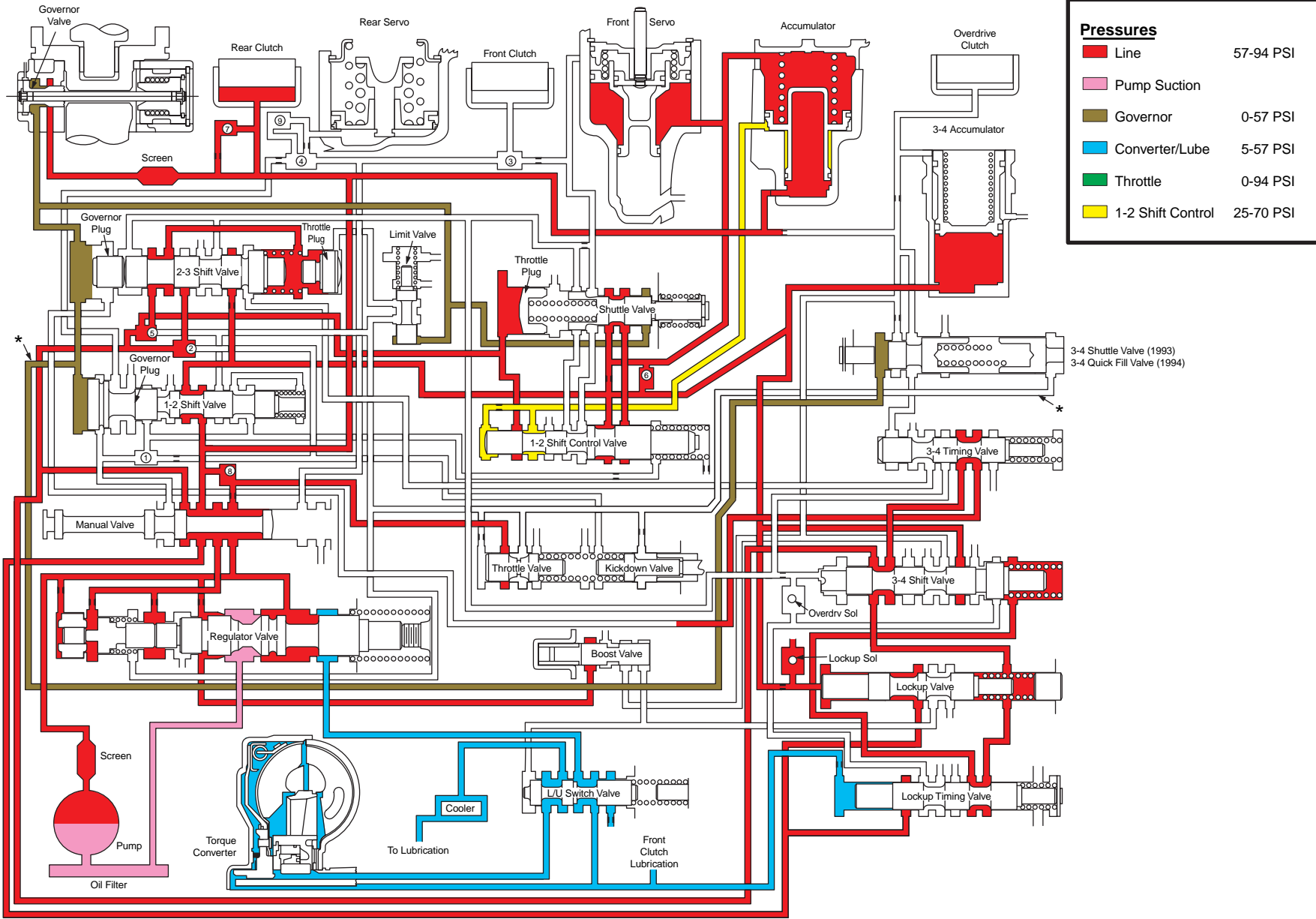

# Chrysler 42RH & 46RH

## 1st Gear - "D" Range

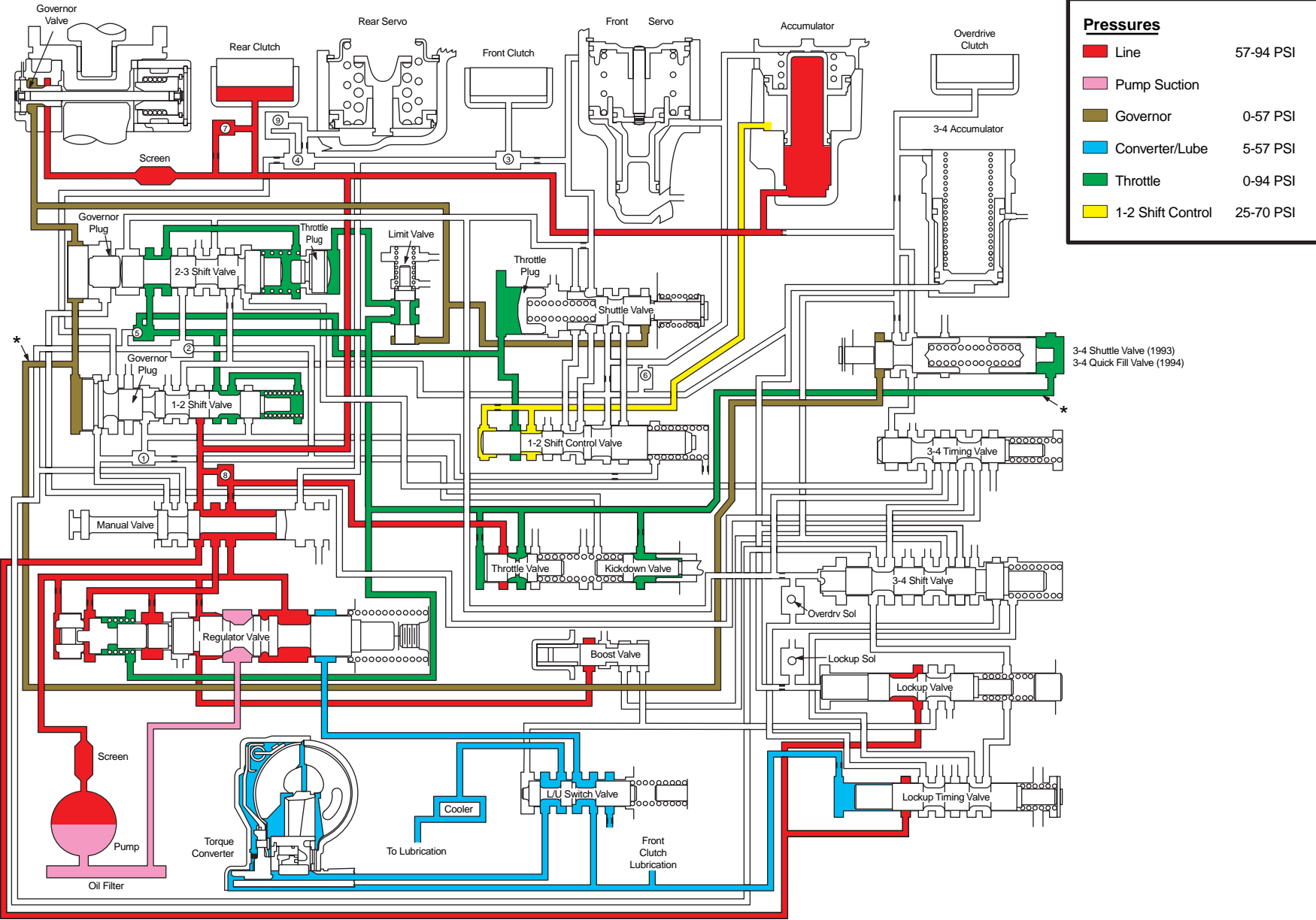

# Chrysler 42RH & 46RH

## 2nd Gear - "D" Range

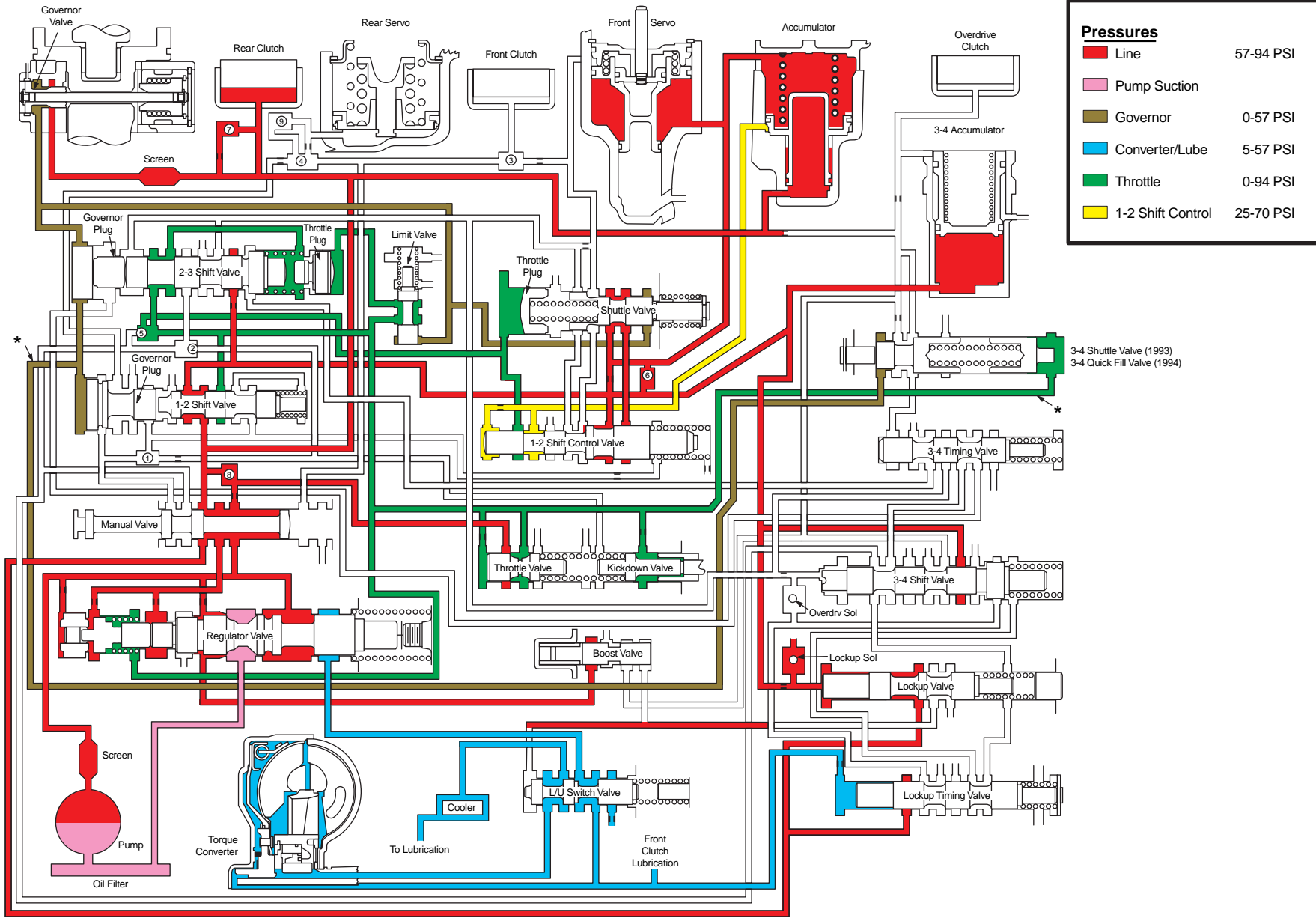

# Chrysler 42RH & 46RH

## 3rd Gear - "D" Range

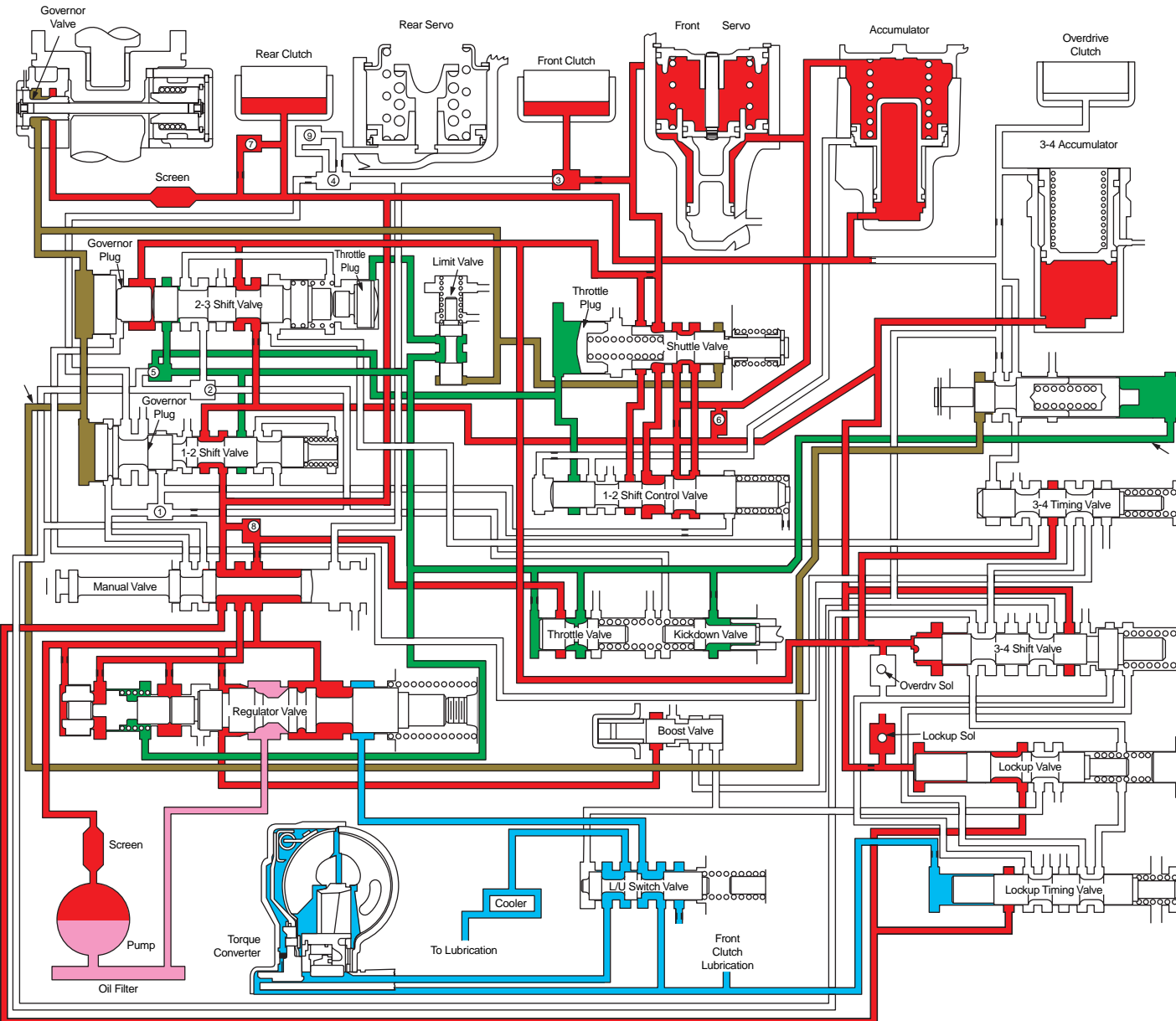

**Pressures**

Red Line	57-94 PSI
Pink Pump Suction	
Brown Governor	0-57 PSI
Blue Converter/Lube	5-57 PSI
Green Throttle	0-94 PSI
Yellow 1-2 Shift Control	25-70 PSI

3-4 Shuttle Valve (1993)  
 3-4 Quick Fill Valve (1994)

# Chrysler 42RH & 46RH

## 4th Gear Overdrive - "D" Range

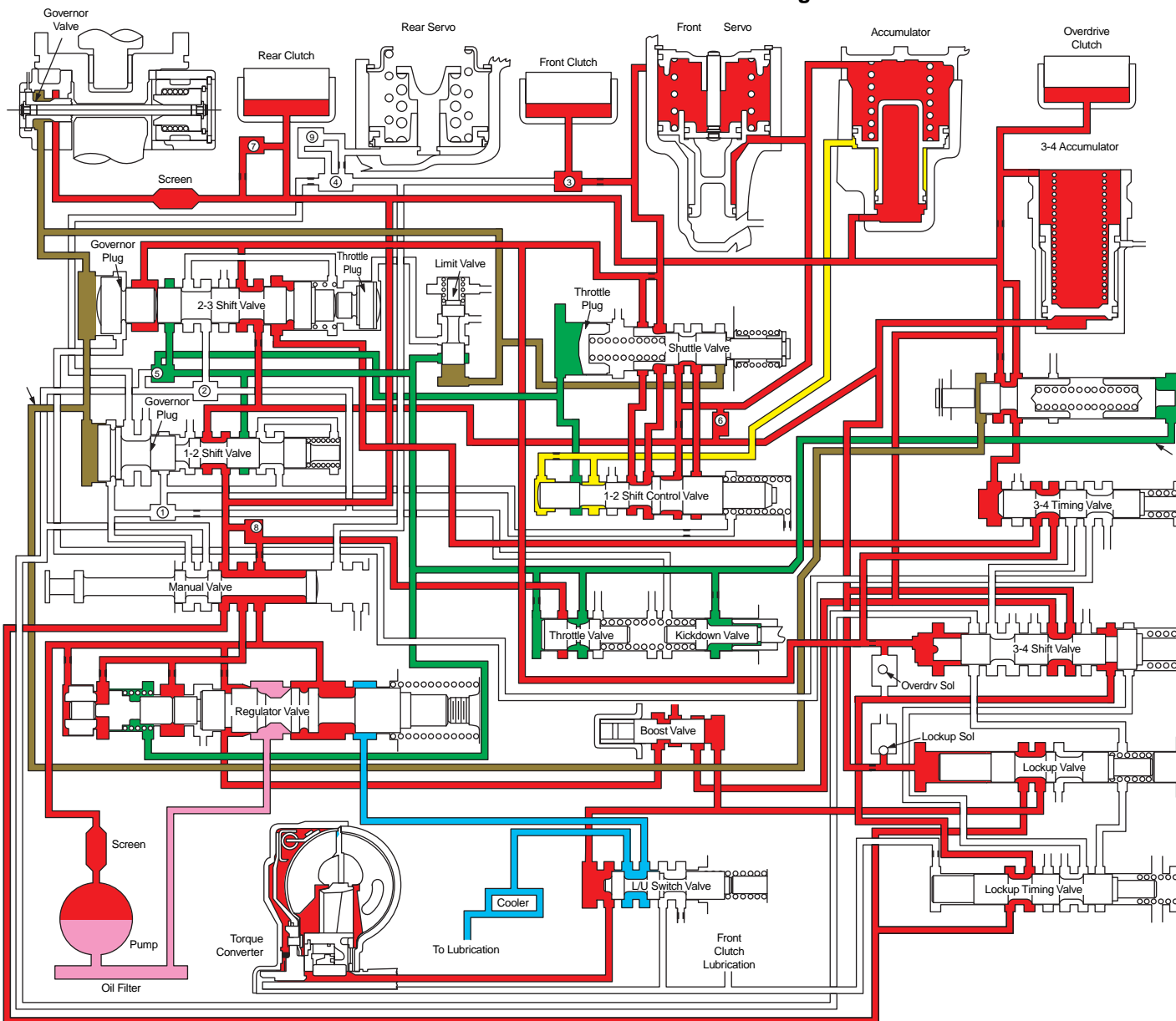

**Pressures**

Line	57-94 PSI
Pump Suction	
Governor	0-57 PSI
Converter/Lube	5-57 PSI
Throttle	0-94 PSI
1-2 Shift Control	25-70 PSI

3-4 Shuttle Valve (1993)  
 3-4 Quick Fill Valve (1994)